

immob.

Phénomène de meubles depuis 1963

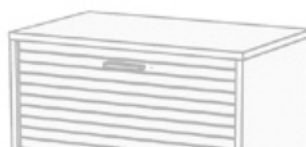

C A T A L O G 2019

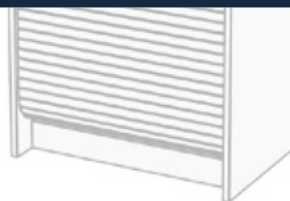

PRODUCTION SITE 16 000 m²



French manufacturer of home and offi



TABLE OF CONTENTS

HAPPY	P. 5 to 9
LUCKY CUISINE	P. 10 to 11
COOK	P. 12 to 13
COOKING	P. 14 to 15
TOP COOK	P. 16 to 17
FAST FOOD.....	P. 18 to 19
VISIO.....	P. 20 to 21
SNACK	P. 22 to 25
LUCKY LIVING-ROOM	P. 26
LUCKY HALL	P. 27
SHOOT	P. 28 to 29
MATHA	P. 30
MATHA DUO.....	P. 31
BOOST	P. 32 to 33
MATHA DRAW.....	P. 34 to 35
ORGA	P. 36 to 41
P@RIS	P. 42 to 43
MUST	P. 44 to 45
COOL.....	P. 46 to 47
SCOUT.....	P. 48 to 49



ce furniture in Cognac area since 1963

LIST OF ABBREVIATIONS

BL	WHITE
AL	ALUMINIUM
CC	LIGHT OAK
TP	TAUPE
HE / HK	BEECH
MK / ME / MN	CHERRY
NO	BLACK
CN / C	NATURAL OAK

The third letter corresponds to the finishing color of a drawer roller-shutter / tambour door / shutter-door

B	WHITE
N	BLACK
M	MANDARINE
A	BEE or ALU



Manufacturer's warranty 2 years and 5 years on MATHA & MATHA DUO.
Non-contractual pictures.
Simmob reserves the right to modify its products without prior notice.
Registered design®.

HAPPY 100C DESK (without drawer)

Structure 16 mm melamine particle boards. Feet 25 mm MDF boards, covered with decor paper. Closed with shutter-door 4 mm MDF boards, covered with decor paper. Half-shuttered compartment. Delivered flat-packed for easy self-assembly.

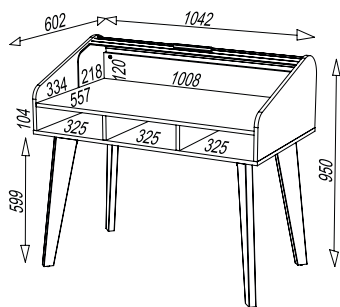

HAPPY100CC



FRONT

HAPPY100CB810



HAPPY100CB



BACK

HAPPY 100C DESK

Dimensions in cm:

L. 104.2 – H. 95 – D. 60.2

Total weight: 30 kgs

3 parcels

Reference pattern:

Product HAPPY100C

+ Feet B or C

+ Roll shutter B, C or 810

Oak structure	C	B	810
Feet	•	•	
Roll shutter	•	•	•

HAPPY 101 DRAWER FOR DESK HAPPY100

This drawer can fit 1,2 or 3 compartments of desk HAPPY100C. Front 16 mm melamine particle boards. Sides and back 12 mm MDF boards, covered with decor paper. Bottom 3 mm MDF boards, covered with decor paper. 1 ABS plastic handle.



HAPPY100CC
+ HAPPY101CN4



HAPPY100CB
+ (2X) HAPPY101BL4



HAPPY100CB
+ (3X) HAPPY101MA4



HAPPY100CB810
+ (3X) HAPPY101AB4

HAPPY101CN4

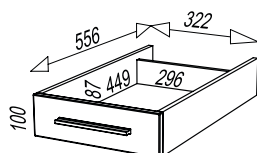

HAPPY 101--4

Dimensions in cm:

L. 32.2 – H. 10 – D. 55.6

Total weight: 30 kgs

1 parcel

Oak structure	CN4	BL4	MA4	AB4
Drawer	•	•	•	•



Designer **Didier VERSAVEL**

HAPPY 220C TV UNIT

Structure 16 mm melamine particle boards. Feet 25 mm MDF boards, covered with decor paper. Closed with shutter-door 4 mm MDF boards, covered with decor paper. 1 ABS plastic handle. 2 compartments. Delivered flat-packed for easy self-assembly.



HAPPY220CCC

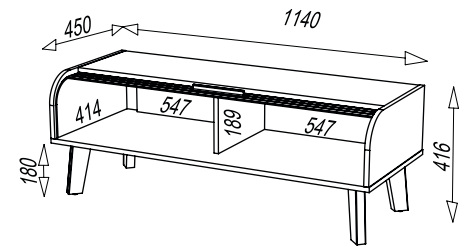

HAPPY 220C TV UNIT

Dimensions in cm:
L. 114 – H. 41.6 – D. 45
Total weight: 21 kgs
3 parcels



HAPPY220CBB



Reference pattern:
Product HAPPY220C
+ Feet B or C
+ Roll shutter B, C or 810



HAPPY220CC810

Oak structure	C	B	810	
Feet	•	•		
Roll shutter	•	•	•	



HAPPY 402C COFFEE-TABLE

Structure 16 mm melamine particle boards. Feet 25 mm MDF boards, covered with decor paper. Closed with 2 shutter-doors (1 on each side) 4 mm MDF boards, covered with decor paper. 2 ABS plastic handles. 4 compartments. Delivered flat-packed for easy self-assembly.



HAPPY402CCC

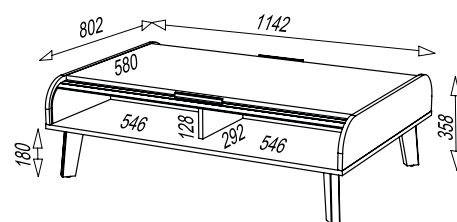

HAPPY 402C COFFEE-TABLE

Dimensions in cm:

L. 114.2 – H. 35.8 – D. 80.2

Total weight: 31 kgs

3 parcels





HAPPY402CC810



HAPPY402CBB

Reference pattern:
Product HAPPY402C
+ Peds B or C
+ Roll-shutter B, C or 810

			
Oak structure	C	B	810
Feet	•	•	
Roll shutter	•	•	•

HAPPY 002C SHOE STORAGE-UNIT (18 pairs)

Structure 16 mm melamine particle boards. Feet 25 mm MDF boards, covered with decor paper. Closed with shutter-door 4 mm MDF boards, covered with decor paper. Shelves for shoes 10 mm MDF boards, covered with decor paper. 1 height-adjustable shelf in top compartment, 2 drop-down doors each one featuring shoe storage system (3 compartments per door). 3 ABS plastic handles, Wall-mounting is advised (fixings provided), Storage for 18 pairs of shoes. Delivered flat-packed for easy self-assembly.



HAPPY002CCCM



HAPPY002CBBA



HAPPY002CCCC

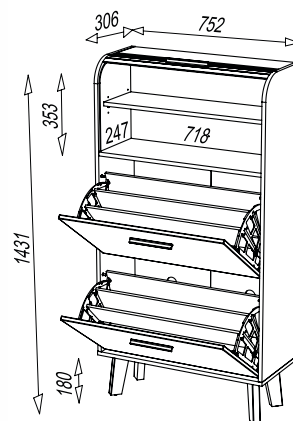

HAPPY 002C
SHOE STORAGE UNIT
 Dimensions in cm:
 L. 75.2 – H. 143.1 – D. 30.6
 Total weight: 42 kgs
 4 parcels



HAPPY002CBBB



HAPPY002CB810B

Reference pattern:
 Product HAPPY002C
 + Feet B or C
 + Roll-shutter B, C or 810
 + Flap C, B, M or A

Oak structure	C	B	M	A	810
Feet	•	•			
Roll-shutter	•	•			•
Flaps	•	•	•	•	



HAPPY 300C SIDEBOARD 3 DRAWERS

Structure 16 mm melamine particle boards. Feet 25 mm MDF boards, covered with decor paper. Closed with shutter-door 4 mm MDF boards, covered with decor paper. 1 height-adjustable shelf, 3 drawers, metallic roller-runners, 4 ABS plastic handles. Delivered flat-packed for easy self-assembly.

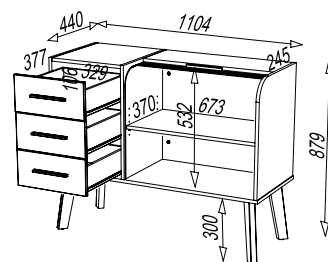

HAPPY 300C
Dimensions in cm:
L. 110.4 – H. 87.9 – D. 44
Total weight: 41 kgs
4 parcels



HAPPY300CCCC



HAPPY300CB810B



HAPPY300CBBB



HAPPY300CCCA



HAPPY300CCBM

Reference pattern:
Product HAPPY300C
+ Feet B or C
+ Roll-shutter B, C or 810
+ Drawers C, B, M or A

	Oak structure	C	B	M	A	810
Feet		•	•			
Roll-shutter		•	•			•
Drawers		•	•	•	•	



LUCKY 131

COUNTERTOP TABLE

LUCKY 131 COUNTERTOP TABLE

Structure 16 mm melamine particle boards ; Table 19 mm melamine particle boards. Back 3 mm MDF boards, covered with decor paper ; Shutter-door 4 mm MDF boards, covered with decor paper. 1 metal tube table stand, 2 metal rods, 3 compartments, 1 ABS plastic handle. Delivered flat-packed for easy self-assembly.

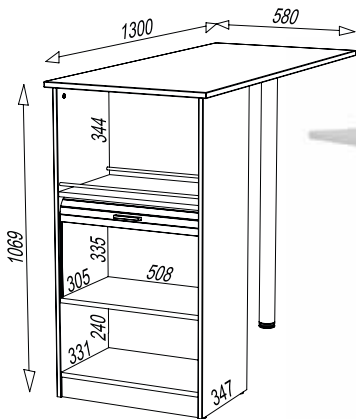

LUCKY131
 Dimensions in cm:
 L. 130 – H. 106.9 – W. 58
 Total weight: 35.5 kgs
 3 parcels



LUCKY 131 BLB



LUCKY 131 BLN



LUCKY 131 CNN



LUCKY 131 CNB



	CNB	CNN	BLB	BLN
Color structure / Color roll shutter + leg + top	Oak + White	Oak + Black	White + White	White + Black
LUCKY 131	•	•	•	•

LUCKY 540

KITCHEN CABINET

LUCKY 540 KITCHEN CABINET TO HANG OR STAND

Structure 16 mm melamine particle boards. Back 3 mm MDF boards, covered with decor paper. Shutter-door 4 mm MDF boards, covered with decor paper. 1 metal rod, 3 compartments., 1 ABS plastic handle, Wall-mounting (fixings provided) or standing cabinet. Delivered flat-packed for easy self-assembly.

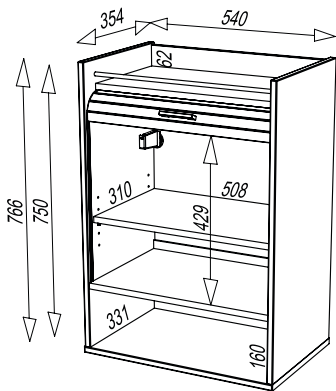

LUCKY540
 Dimensions in cm:
 L. 54 – H. 76.6 – D. 35.4
 Total weight: 22 kgs
 2 parcels



LUCKY 540 BLN



LUCKY 540 CNN



LUCKY 540 BLB



LUCKY 540 CNN



LUCKY 540 CNB

	CNB	CNN	BLB	BLN
Color structure / Color roll shutter	Oak + White	Oak + Black	White + White	White + Black
LUCKY 540	•	•	•	•



COOK

KITCHEN CABINETS TO HANG OR STAND

Specifically designed to complete standard kitchen furniture. Placed on the kitchen worktop, with or without the inside shelf. Structure 16 mm melamine particle boards. Closed with shutter-door 4mm MDF boards, covered with decor paper. 1 ABS plastic handle, 2 Adjustable hangers, Wall mounting (fixings provided) or standing cabinets. Delivered flat-packed for easy self-assembly.

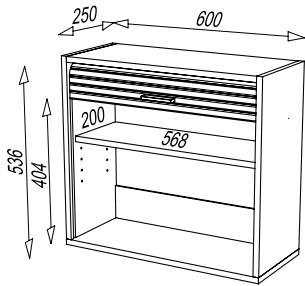

COOK056 - L 60 cm
 1 adjustable-shelf
 Dimensions in cm:
 L. 60 H. 53.6 – D. 25
 Total weight: 14 kgs
 1 parcel



COOK 056 AL

60 CM LARGE



COOK 056 BL

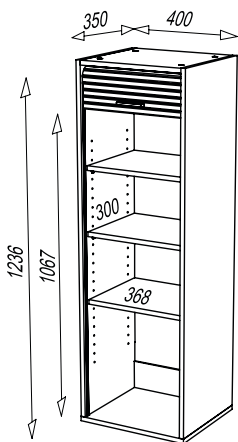

COOK124 - L 40 cm
 3 adjustable shelves
 Dimensions in cm:
 L. 40 H. 123.6 – D. 35
 Total weight: 23 kgs
 1 parcel



COOK 124 BL

40 CM LARGE



COOK 124 AL

	AL	BL
COLORS	Alu	White
COOK 056	•	•
COOK 124	•	•
COOK 126	•	•





COOK 126 BL

60 CM LARGE



COOK 126 AL

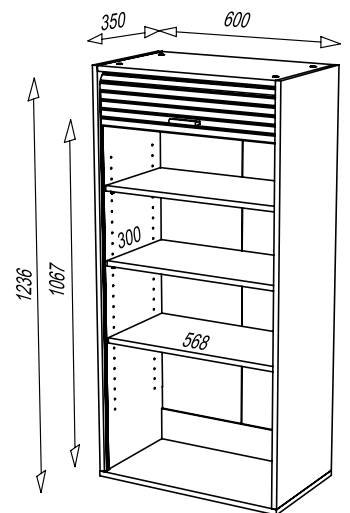

COOK126 - L 60 cm
3 adjustable shelves
Dimensions in cm:
L. 60 H. 123.6 – D. 35
Total weight: 30 kgs
1 parcel

NANTES 272 KITCHEN ISLAND WITH ROTATING TABLE

Structure 16 mm and 19 mm melamine particle boards. Closed with shutter-door 4 mm MDF boards, covered with plain or printed decor paper. 1 ABS plastic handle, 2 height-adjustable shelves, 22 mm thick rotating table on metal tube leg with caster and brake. Top compartment with 2 plastic tube feet diam 50 mm, 4 plastic feet. Reversible (when assembling). Delivered flat-packed for easy self-assembly.

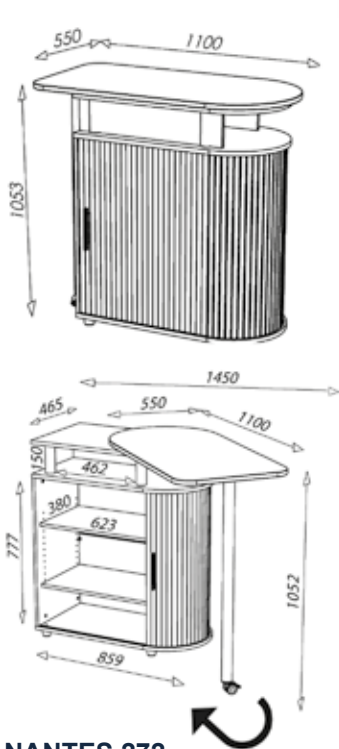

NANTES 272

Dimensions in cm (Folded):

L. 110 – H. 105.3 – D. 55

Dimensions in cm (Unfolded):

L. 145 – H. 105.3 – D. 55

Total weight: 55 kgs

3 parcels

NANTES 272 CNB



NANTES 272 BL

NANTES 272 B 701

NANTES 272 BLA



NANTES 262 KITCHEN ISLAND WITH ROTATING TABLE 360°

Structure 16 mm and 19 mm melamine particle boards. Back 3 mm MDF boards, covered with decor paper. 2 shutter doors 4 mm MDF boards, covered with decor paper. 19 mm thick rotating table on metal tube leg with caster and brake. 2 height-adjustable shelves, 2 ABS plastic handles, 4 ABS plastic feet. Table rotates 360° around storage cabinet. Delivered flat-packed for easy self-assembly.

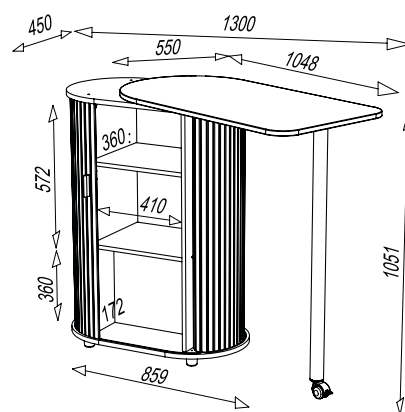

NANTES 262

Dimensions in cm (Folded):

L. 104.8 – H. 105.1 – D. 55

Dimensions in cm (Unfolded):

L. 130 – H. 105.1 – D. 55

Total weight: 43 kgs

2 parcels



NANTES 262 CNB

SNACK 275 BLA COMPACT KITCHEN STORAGE WITH PIVOTING TABLE

Structure 16 mm melamine particle boards. White finishings and white back-panels. Large storage unit closed with 2 shutter-doors 4 mm MDF boards, covered with decor paper. 2 ABS plastic handles. Top compartment with 1 height-adjustable shelf. Bottom compartment with 2 height-adjustable shelves. Side cabinet with 2 height-adjustable shelves and 2 doors. 22 mm thick swivel table on metal tube leg with caster and brake. Delivered flat-packed for easy self-assembly.

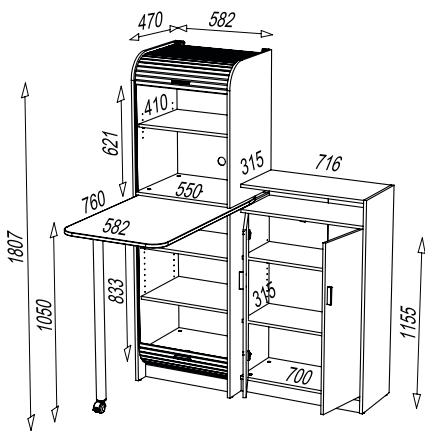

SNACK 275 BLA

Dimensions in cm (Folded):

L. 131 – H. 180.7 – D. 60

Effective dimensions table top:

L. 76 – D. 58.2

Total weight: 85 kgs

3 parcels



SNACK 275 BLA



COOK 105 BLA KITCHEN ISLAND WITH ROTATING TABLE 360°

Structure 16 mm and 19 mm melamine particle boards. White finishings. Closed with 2 roll-shutters medium density wood-fibre boards (MDF), covered with decor paper. 2 ABS plastic handles. Storage cabinet with 2 height-adjustable shelves. 22 mm thick rotating table on metal tube leg with caster and brake. 4 ABS plastic feet. Delivered flat-packed for easy self-assembly.

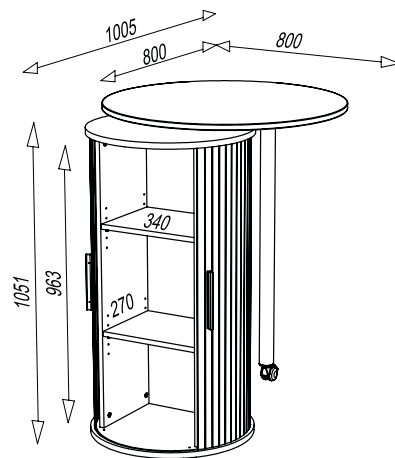

COOK 105 BLA
Dimensions in cm:
Diam 80 – H.105.1
Amplitude:
Mini 80 – maxi 100.5
Total weight: 43 kgs
3 parcels



COOK 105 BLA



FAST FOOD KITCHEN FURNITURE

Structure 16 mm melamine particle boards. Closed with 2 shutter-doors 4 mm MDF boards, covered with decor paper. 2 ABS plastic handles. Delivered flat-packed for easy self-assembly.

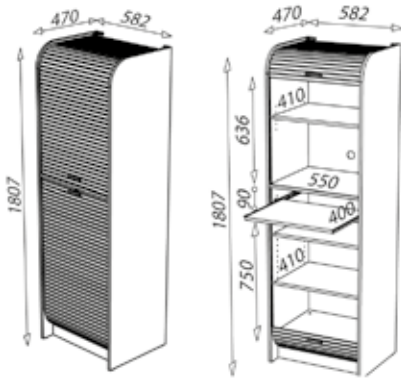

NANTES 260
 Kitchen storage cabinet
 Top compartment with
 1 height-adjustable shelf
 Bottom compartment with
 2 height-adjustable
 shelves + 1 sliding shelf
 Dimensions in cm:
 L. 58.2 – H. 180.7 – D. 47
 Total weight: 58 kgs
 2 parcels



NANTES 260 HKB



NANTES 260 BLA





NANTES 260 HKB

SNACK 269 HKB

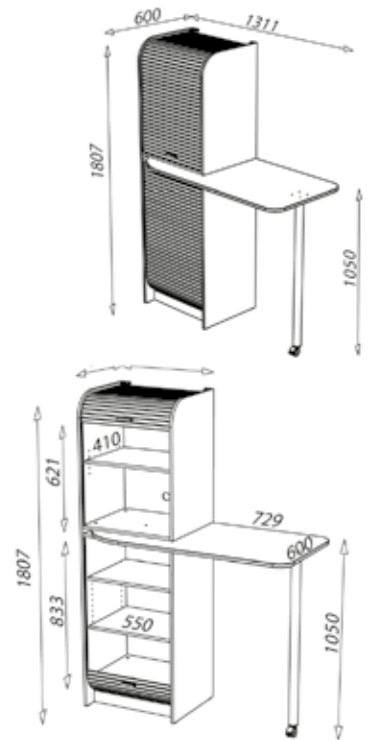

SNACK 269
 Kitchen storage cabinet
 with pivoting table 90°
 Top compartment with
 1 height-adjustable shelf.
 Bottom compartment with
 2 height-adjustable
 shelves+ 1 sliding shelf.
 Pivoting table on metal
 tube leg with caster and
 brake
 Dimensions in cm
 (structure only):
 L. 131.1 – H. 180.7 – D. 60
 Total weight: 63 kgs
 2 parcels



SNACK 269 BLA



SNACK 269 HKB

VISIO 096

BAR DRINKS CABINET

VISIO 096

BAR DRINKS CABINET - LENGHT 97 CM - PLAIN OR PRINTED

Structure 16 mm melamine particle boards. Front MDF board, plain or printed. 1 height-adjustable shelf. 1 semi-fixed shelf. 1 Epoxy-painted metal footrest. 1 PVC foot. Delivered flat-packed for easy self-assembly.

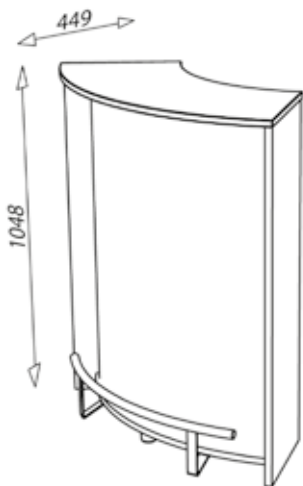

VISIO 096 NOB



VISIO 096 BL



VISIO 096 CNB



VISIO 096 NOB

VISIO 096
Dimensions in cm:
L. 96.7 – H. 104.8 – D. 44.9
Total weight: 29 kgs
2 parcels



CNB

BL

NOB



VISIO 096 BL 751



VISIO 096 BL 500



VISIO 096 BL 911



VISIO 096 NO 508



VISIO 096 NO 701



VISIO 096 CN 216

SNACK 106

BAR DRINKS CABINET

SNACK 106 MULTIPURPOSE COUNTER - LENGHT 107 CM - PLAIN OR PRINTED

Structure 16 mm melamine particle boards. Front MDF board, plain or printed. 2 height-adjustable shelves. 1 Epoxy-painted metal footrest . 4 nail pads. Delivered flat-packed for easy self-assembly.



SNACK 106 BL

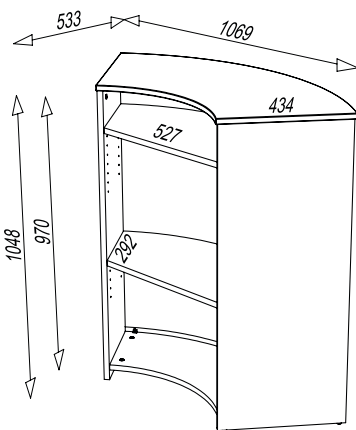

SNACK 106
Dimensions in cm:
L. 106.9 - H. 104.8 -D. 53.3
Total weight: 35 kgs
2 parcels



SNACK 106 N0B





SNACK 106 NOB



SNACK 106 BL 943



SNACK 106 NO 911



SNACK 106 NO 922



SNACK 106 NO 942



SNACK 106 BL 451

SNACK 134 MULTIPURPOSE COUNTER - LENGHT 135 CM - PLAIN OR PRINTED

Structure 16 mm melamine particle boards. Front MDF board, covered with plain or printed decor paper. 1 fixed-shelf. 2 height-adjustable shelves. 1 Epoxy-painted metal footrest. 1 PVC foot. 4 nail pads. Delivered flat-packed for easy self-assembly.

SNACK 135 MULTIPURPOSE COUNTER + 2 DOORS

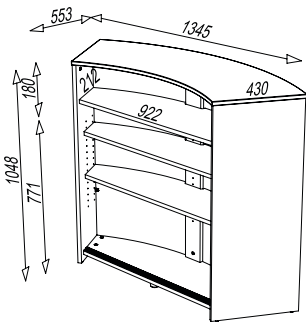

SNACK 134
 Reception desk, checkout,
 kitchen or bar counter 3 pers.
 Dimensions in cm:
 L. 134.5 – H. 104.8 – D. 53.3
 Total weight: 45 kgs
 2 parcels



SNACK 134 BL

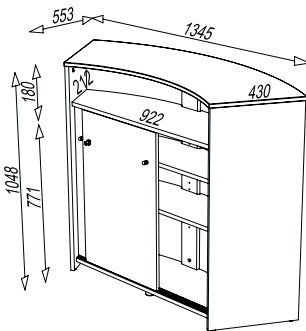

SNACK 135
 Sliding-doors
 16 mm melamine particle
 boards mounted on rails
 2 ABS plastic handles + locker
 Dimensions in cm each door:
 L. 49 – H. 76.5
 Total weight: 10 kgs
 1 parcel



SNACK 134 BL



SNACK 135 BL





SNACK 134 NOB



SNACK 135 NOB



SNACK 134 ET 135 NOB



SNACK 134 ET 135 NO 911



SNACK 134 ET 135 BL 451



SNACK 134 ET 135 BL 941

LUCKY 600

COFFEE-TABLE

LUCKY 600 COFFEE-TABLE 4 SHUTTER-DOORS

Structure 16 mm melamine particle boards. Closed with 4 shutter-doors 4 mm MDF boards, covered with decor paper. 4 ABS plastic handles. 4 ABS feet. 2 compartments. Delivered flat-packed for easy self-assembly.

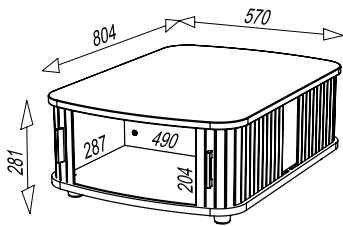

LUCKY600

Dimensions in cm:
L. 80.4 – H. 28.1 – W. 57
Total weight: 19 kgs
2 parcels



LUCKY 600 CNC



LUCKY 600 CNB



LUCKY 600 CNN



LUCKY 600 BLC



LUCKY 600 BLB



LUCKY 600 BLB



LUCKY 600 BLN



	CNB	CNN	CNC	BLB	BLN	BLC
Color structure / Color shutter-doors	Oak + White	Oak + Black	Oak + Oak	White + White	White + Black	White + Oak
LUCKY 600	•	•	•	•	•	•

LUCKY 300 SHOE CABINET - SEAT

Structure 16 mm melamine particle boards. Rigid structure for sitting position. Shelves 4 mm MDF boards, covered with decor paper. 1 drop-down door featuring shoe storage system (3 compartments per door). 1 ABS plastic handle. Storage for 9 pairs of flat shoes. Delivered flat-packed for easy self-assembly.

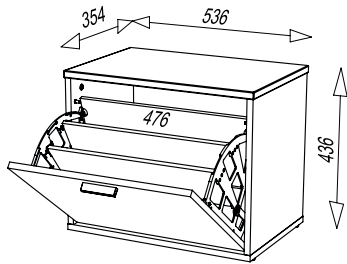

LUCKY300
Dimensions in cm:
L. 53.6 – H. 43.6 – D. 35.4
Total weight: 17 kgs
1 parcel



LUCKY 300 BLN



LUCKY 300 CNN



SHOOT 120

SHOE CABINET

SHOOT 120 SHOE CABINET - PLAIN OR PRINTED

Structure 16 mm melamine particle boards. Closed with shutter-door 4 mm MDF boards, covered with plain or printed decor paper. 1 ABS plastic handle, 2 magnets. 6 shelves 8mm, height and position-adjustable. Storage for 21 pairs of flat shoes. Delivered flat-packed for easy self-assembly.

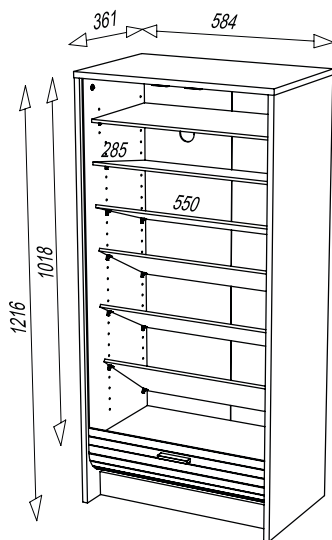
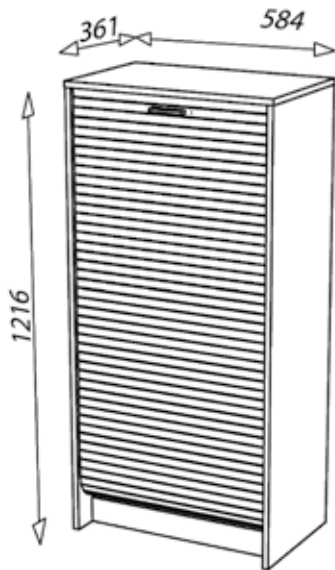

SHOOT 120
Dimensions in cm:
L. 58.4 – H. 121.6 – D. 36.1
Total weight: 27 kgs
2 parcels



SHOOT 120 CN



SHOOT 120 NO





SHOOT 120 BL



SHOOT 120 NO 912



SHOOT 120 NO 201



SHOOT 120 BL 217



SHOOT 120 BL 750



SHOOT 120 CN 200



SHOOT 120 NO 504



SHOOT 120 BL 500

MATHA 080, 110, 141, 171 ROLL TOP CABINETS

Structure 16 mm melamine particle boards. Closed with shutter-door 4 mm MDF boards, covered with decor paper. 1 locker. Height-adjustable shelves 5 mm and rack for A4 suspension files. 4 nail pads. Delivered flat-packed for easy self-assembly.



MATHA 171 HK



MATHA 080 BL



MATHA 110 MK



MATHA 141 CN

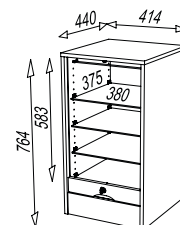

MATHA 080
3 height-adjustable shelves
+ 1 fixed shelf
Dimensions in cm:
L. 41.4 – H. 76.4 – D. 44
Total weight: 16 kgs
1 parcel

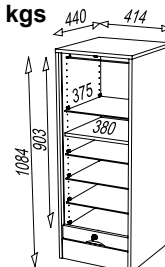

MATHA 110
4 height-adjustable shelves
+ 2 fixed shelves
Dimensions in cm:
L. 41.4 – H. 108.4 – D. 44
Total weight: 21 kgs
1 parcel

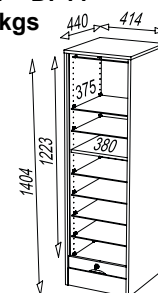

MATHA 141
6 height-adjustable shelves
+ 2 fixed shelves
Dimensions in cm:
L. 41.4 – H. 140.4 – D. 44
Total weight: 30 kgs
1 parcel

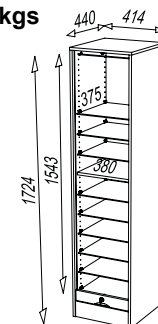

MATHA 171
8 height-adjustable shelves
+ 2 fixed shelves
Dimensions in cm:
L. 41.4 – H. 172.4 – D. 44
Total weight: 33 kgs
1 parcel



	BL	CN	HK	MK
080	•		•	•
110	•		•	•
141	•	•	•	•
171	•		•	•



MATHA DUO 082, 112, 142, 177 DOUBLE ROLL TOP CABINETS

Structure 16 mm melamine particle boards. Closed with shutter-door 4 mm MDF boards, covered with decor paper. 1 locker. Height-adjustable shelves 5 mm and 2 racks for A4 suspension files. Delivered flat-packed for easy self-assembly.

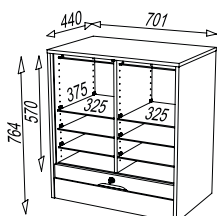

MATHA 082
6 height-adjustable shelves
+ 2 fixed shelves
Dimensions in cm:
L. 70.1 – H. 76.4 – D. 44
Total weight: 29 kgs
1 parcel

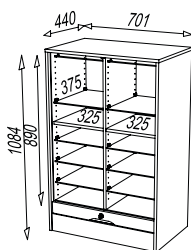

MATHA 112
8 height-adjustable shelves
+ 4 fixed shelves
Dimensions in cm:
L. 70.1 – H. 108.4 – D. 44
Total weight: 37 kgs
1 parcel

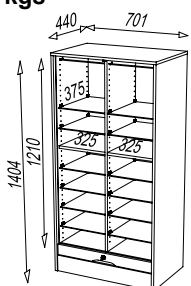

MATHA 142
12 height-adjustable shelves
+ 4 fixed shelves
Dimensions in cm:
L. 70.1 – H. 140.4 – D. 44
Total weight: 47 kgs
2 parcels

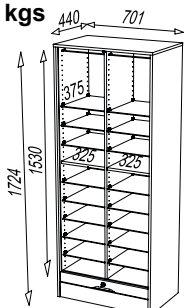

MATHA 177
16 height-adjustable shelves
+ 4 fixed shelves
Dimensions in cm:
L. 70.1 – H. 172.4 – D. 44
Total weight: 56 kgs - 2 parcels



MATHA 177 MK



MATHA 112 BL



MATHA 142 HK



MATHA 082 BL



	BL	HK	MK
082	•	•	•
112	•	•	•
142	•	•	•
177	•	•	•



BOOST 105

ROLL TOP CABINET

BOOST 105 ROLL TOP CABINET PLAIN OR PRINTED

Structure 16 mm melamine particle boards. Closed with shutter-door 4 mm MDF boards, covered with plain or printed decor paper 1 locker. 4 height-adjustable shelves 5mm. 1 fixed-shelf 16 mm. Delivered flat-packed for easy self-assembly.

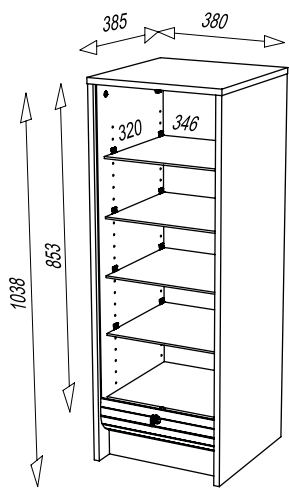

BOOST 105 CN



BOOST 105 BL



BOOST 105
Dimensions in cm:
L. 38 – H. 103.8 – D. 38.5
Total weight: 19 kgs
2 parcels



BOOST 105 NO



CN

BL

NO





BOOST 105 CN 750



BOOST 105 BL 911



BOOST 105 CN 500



BOOST 105 BL 562



BOOST 105 NO 504



BOOST 105 BL 700



BOOST 105 BL 913



BOOST 105 NO 912



BOOST 105 NO 217

MATHA DRAW 412, 413, 414 FILING CABINETS WITH DRAWERS

Structure 16 mm melamine particle boards Drawers for A4 suspension files (25 files per drawer), on metallic roller-runners, with ABS plastic handles. Delivered flat-packed for easy self-assembly.



MATHA 412 AL



MATHA 414 HK



MATHA 413 NO



MATHA 412 MK



MATHA 414 BL



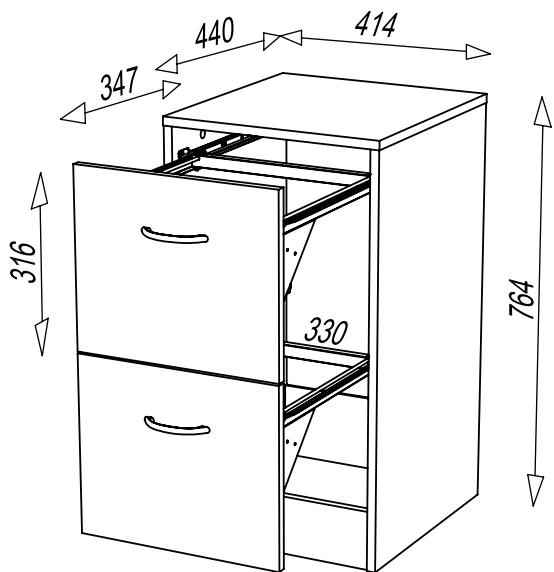

MATHA 412

2 drawers

Dimensions in cm:

L. 41.4 – H. 76.4 – D. 44

Total weight: 18 kgs

1 parcel

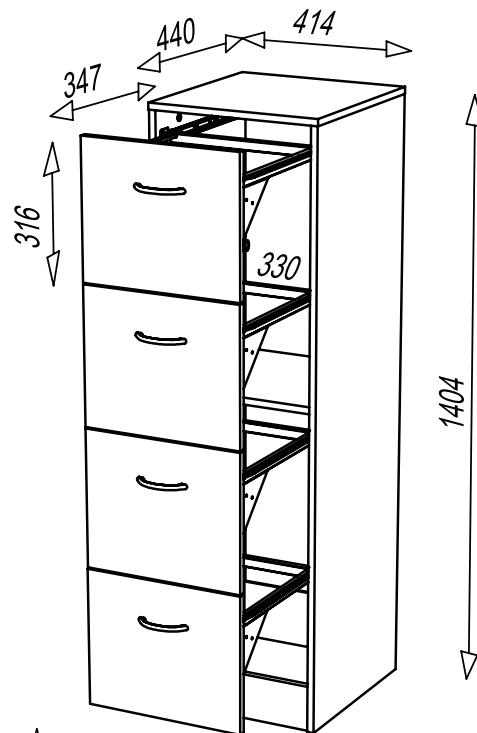

MATHA 414

4 drawers

Dimensions in cm:

L. 41.4 – H. 140.4 – D. 44

Total weight: 33 kgs

1 parcel

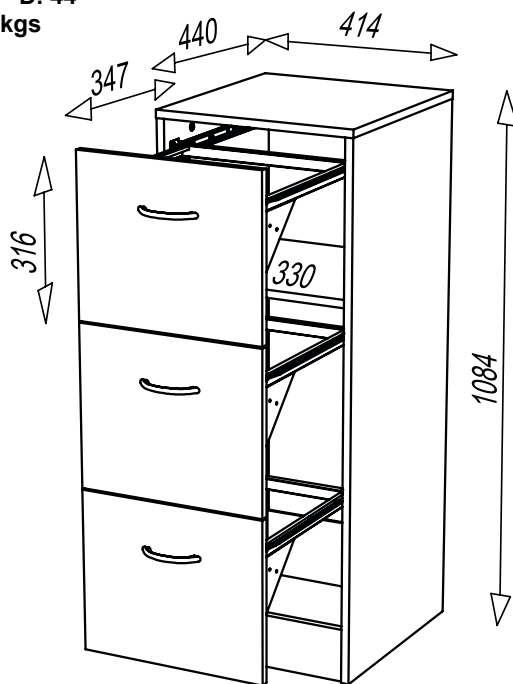

MATHA 413

3 drawers

Dimensions in cm:

L. 41.4 – H. 108.4 – D. 44

Total weight: 26 kgs

1 parcel



	BL	AL	HK	MK	NO
412	•	•	•	•	
413	•	•	•	•	•
414	•	•	•	•	•



ORGA 070

OFFICE SHUTTER STORAGE TROLLEY

ORGA 070

OFFICE SHUTTER STORAGE TROLLEY H. 65 CM – PLAIN OR PRINTED

Structure 16 mm melamine particle boards. Closed with shutter-door 4 mm MDF boards, covered with plain or printed decor paper . 1 Locker.1 ABS plastic handle. 2 high impact polystyrene drawers and 1 rack for A4 suspension files. On 4 casters. Delivered flat-packed for easy self-assembly

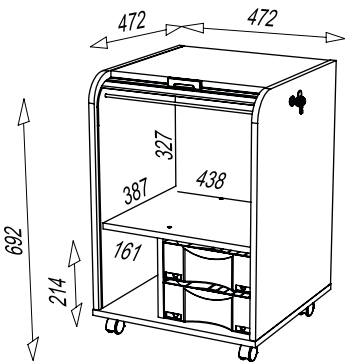

ORGA 070

Dimensions in cm:

L. 47.2 – H. 69.2 – D. 47.2

Total weight: 21 kgs

2 parcels



ORGA 070 BLB



ORGA 070 CNB



ORGA 070 ALB



ORGA 070 NON



	BLB	NON	CNB	ALB
070	•	•	•	•

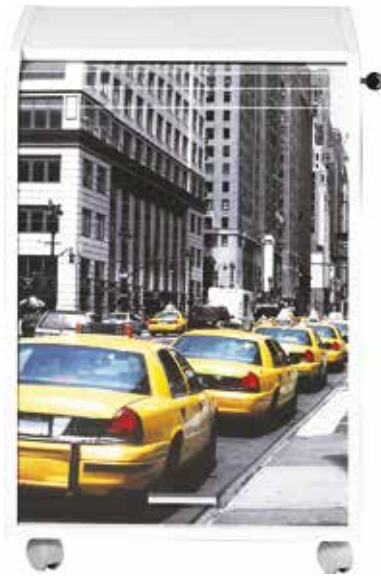

ORGA 070 BLB 503



ORGA 070 CNB 505



ORGA 070 CNB 751



ORGA 070 BLB 301



ORGA 070 NON 500



ORGA 070 NON 701



ORGA 070 BLB 217

ORGA 110

LARGE OFFICE SHUTTER STORAGE TROLLEY

ORGA 110

LARGE OFFICE SHUTTER STORAGE TROLLEY H. 117 CM – PLAIN OR PRINTED

Structure 16 mm melamine particle boards. Closed with shutter-door 4 mm MDF boards, covered with plain or printed decor paper . 1 Locker. 1 ABS plastic handle. 3 high impact polystyrene drawers and 1 rack for A4 suspension files. On 4 casters. Delivered flat-packed for easy self-assembly.

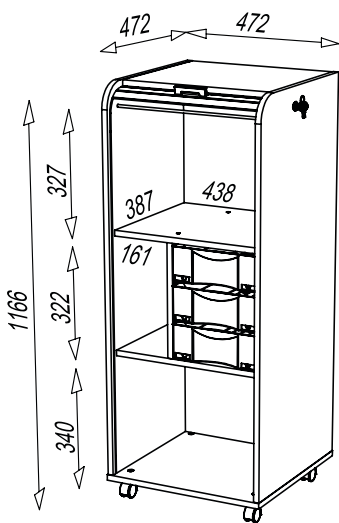

ORGA 110
 Dimensions in cm:
 L. 47.2 – H. 116.6 – D. 47.2
 Total weight: 33 kgs
 3 parcels



ORGA 110 CNB



ORGA 110 ALB



ORGA 110 BLB



ORGA 110 NON



				
	ALB	BLB	NON	CNB
110	•	•	•	•



ORGA 110 CNB 504



ORGA 110 CNB 700



ORGA 110 NON 506



ORGA 110 BLB 500



ORGA 110 NON 301



ORGA 110 BLB 912



ORGA 110 NON 505

ORGA 140

OFFICE SECRETARY DESK

ORGA 140

OFFICE SECRETARY DESK - PLAIN OR PRINTED

Structure 16 mm melamine particle boards. Closed with shutter-door 4 mm MDF boards, covered with plain or printed decor paper. 1 locker. 1 ABS plastic handle. 1 sliding-shelf on metallic roller-runners. 1 fixed shelf. 2 high impact polystyrene drawers. On 4 casters, 2 of them with brake. Delivered flat-packed for easy self-assembly.

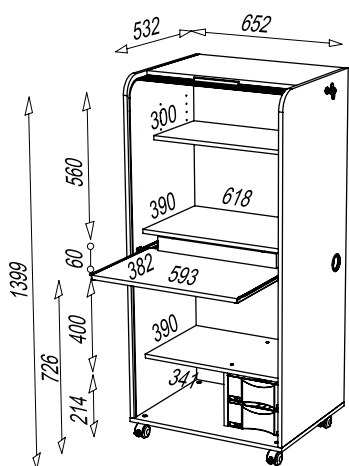

ORGA 140

Dimensions in cm:

L. 65.2 – H. 139.9 – D. 53.2

Total weight: 48 kgs

3 parcels



ORGA 140 CNB



ORGA 140 ALB



ORGA 140 TPB



140	BLB	NON	ALB	TPB	CNB
	•	•	•	•	•





ORGA 140 NON



ORGA 140 BLB



ORGA 140 BLB 750



ORGA 140 NON 500



ORGA 140 BLB 301



ORGA 140 TPB 912



ORGA 140 CNB 700

PARIS 572

OFFICE SECRETARY DESK WITH SHUTTER-DOOR L. 60 CM

Structure 16 mm melamine particle boards. Closed with shutter-door 4 mm MDF boards, covered with decor paper. 1 locker. Delivered flat-packed for easy self-assembly.

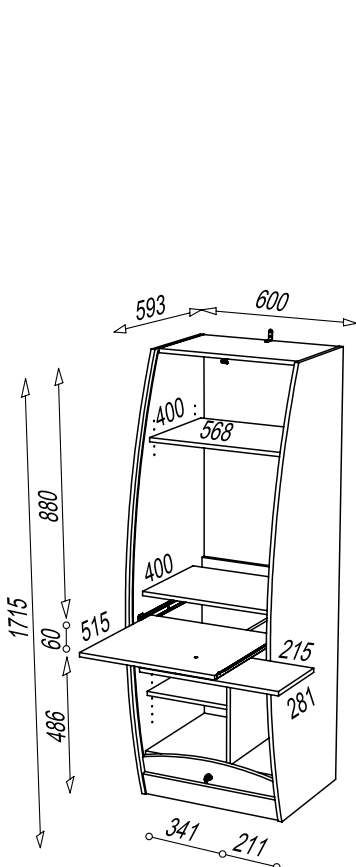

PARIS 572 MK



PARIS 572 BL

PARIS 572

1 keyboard sliding-shelf on metallic roller runners, pivoting top for mouse
 Top compartment with height-adjustable shelf
 2 bottom compartments, 1 of them with height-adjustable shelf
 Dimensions in cm:
 L. 60 – H. 171.5 – D. 59.3
 Total weight: 52 kgs
 2 parcels



MK BL HK



PARIS 580

OFFICE SECRETARY DESK WITH SHUTTER-DOOR L. 80 CM

Structure 16 mm melamine particle boards . Closed with shutter-door 4 mm MDF boards, covered with decor paper. 1 locker. Delivered flat-packed for easy self-assembly.



PARIS 580 BL



PARIS 580 HK

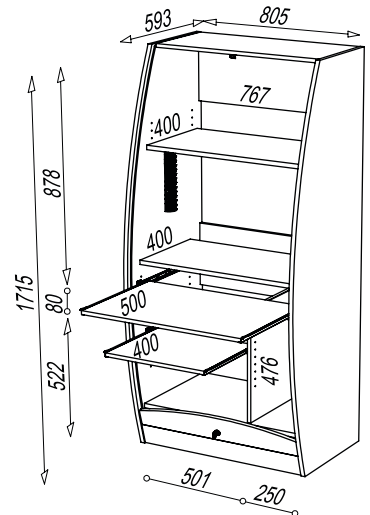

PARIS 580

- 1 keyboard sliding-shelf on metallic roller runners
 - Top compartement with height-adjustable shelf and CDs rack.
 - 2 bottom compartements, 1 of them with sliding-shelf on roller runners for printer,
 - 1 with height-adjustable shelf
- Dimensions in cm:
L. 80.5 – H. 171.5 – D. 59.3
Total weight: 69,5 kgs
2 parcels



MK

BL

HK



MUST

OFFICE SECRETARY DESK WITH SHUTTER-DOOR

MUST 095

OFFICE SECRETARY DESK WITH SHUTTER-DOOR – PLAIN OR PRINTED

Structure 16 mm melamine particle boards Closed with shutter-door 4 mm MDF boards, covered with plain or printed decor paper. 1 locker ; 1 ABS plastic handle. Large sliding desktop and 1 sliding shelf for pinter on metallic roller-runners. Compartment with height-adjustable shelf. On 4 casters, 2 of them with brake. Delivered flat-packed for easy self-assembly.

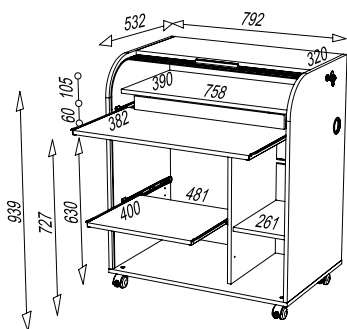

MUST 095

Dimensions in cm:

L. 79.2 – H. 93.9 – D. 53.2

Total weight: 42 kgs

2 parcels



MUST 095 NO



MUST 095 BL



095	BL	NO
	•	•



MUST 095 BL



MUST 095 BL 500

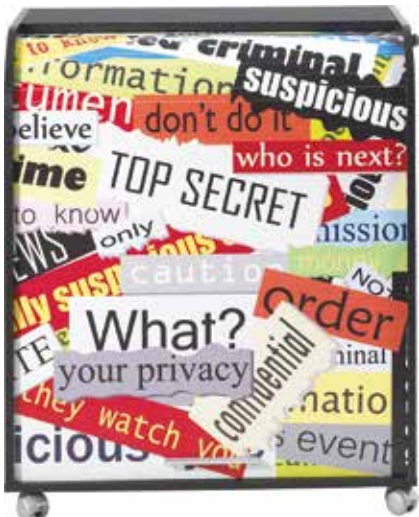

MUST 095 NO 300



MUST 095 NO 400



MUST 095 BL 217

COOL 100

COMPACT STORAGE CABINET WITH SHUTTER-DOOR

COOL 100

COMPACT STORAGE CABINET WITH SHUTTER-DOOR AND ROTATING TOP-TABLE – PLAIN OR PRINTED

Structure 16 mm melamine particle boards Closed with shutter-door 4 mm MDF boards, covered with plain or printed decor paper. 1 ABS plastic handle. 1 height-adjustable sliding shelf Rotating top-table on metal tube-leg with caster and brake. 4 plastic feet. Reversible (when assembling). Delivered flat-packed for easy self-assembly.

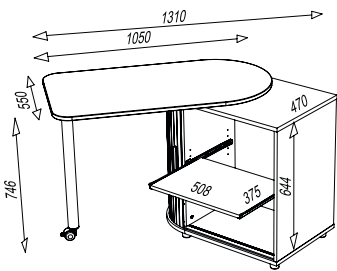

COOL 100 CN

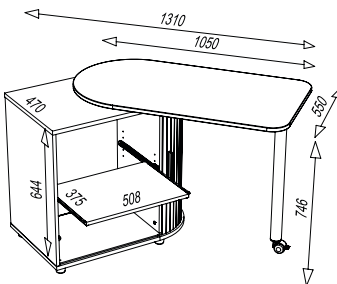

COOL 100 BL



COOL 100
 Dimensions in cm (folded):
 L. 105 – H. 74.7 – D. 55
 Total weight: 35 kgs
 2 parcels



COOL 100	BL	NO	CN	AL
	•	•	•	•





COOL 100 NO



COOL 100 BL 801



COOL 100 NO 800



COOL 100 AL 701



COOL 100 CN 753



COOL 100 BL 508



COOL 100 NO 300

SCOUT 122

DESK

SCOUT 122 DESK

Structure 16 mm melamine particle boards. 2 storage cabinets closed with shutter-door 4 mm MDF boards, covered with plain or printed decor paper. Each cabinet features : 1 ABS plastic handle. 2 shelves, 1 of them height-adjustable. 1 rack for A4 suspension files. Delivered flat-packed for easy self-assembly.



SCOUT 122 BL

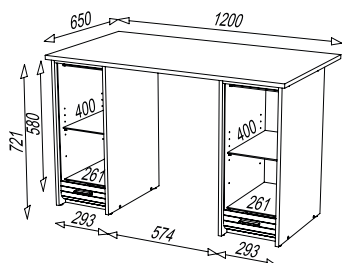

SCOUT 122

Dimensions in cm:
L. 120 – H. 74 – D. 65
Total weight: 42 kgs
5 parcels



SCOUT 122 NO





SCOUT 122 BL 505



SCOUT 122 NO 217



SCOUT 122 BL 503



SCOUT 122 NO 750



SCOUT 122 NO 500

GENERAL TERMS AND CONDITIONS OF SALE

Those general terms and conditions of sale shall apply to all orders for furniture placed by the Purchaser (Customer) to the Seller (SIMMOB). Any Purchaser's general terms and conditions of purchase should only apply insofar as the Seller (SIMMOB) has consented to them in writing. Placing an order entails express acceptance by the Purchaser, of those general terms and conditions of sale. In the event of deviations between the English version of those general terms and conditions of sale and any version in another language, the English text prevails.

ACCEPTANCE OF ORDERS:

Orders placed by the Purchaser do not bind the Seller (SIMMOB) or become firm and final until they are confirmed in writing by the Seller (SIMMOB). The order confirmation shall be regarded as the firm and final agreement on the specifications, quantity, price, procedure for payment, time and place of delivery for the ordered furniture.

Any amendment to the order requested by the Purchaser is conditional upon the Seller's (SIMMOB) written agreement.

Any cancellation, return or refund of the order requested by the Purchaser is conditional upon the Seller's (SIMMOB) written agreement.

PRODUCTS:

SIMMOB furniture is sold disassembled and is to be assembled by the Purchaser.

Technical information and assembly guidelines are available on simple request.

The Seller (SIMMOB) reserves the right to make changes in design, construction, materials and dimensions, or to discontinue products without prior notice.

PRICES:

All prices are indicated on the Seller's (SIMMOB) price-list.

The costs for packaging are included in the prices.

All prices are in Euros, exclusive of any taxes, and quoted on the basis of EX WORKS Matha, France (EXW, Incoterms 2010), unless otherwise agreed.

All additional services such as transportation, shall be supported by the Purchaser, and invoiced in addition.

All taxes and duties of any nature required by a governmental authority, state or local, either directly or indirectly, upon the sale or transportation of the products included in the invoice, shall be supported by the Purchaser, and invoiced in addition.

The Seller (SIMMOB) reserves the right to amend prices so as to incorporate currency fluctuations or unforeseeable variations in the cost of materials, energy or labor, without Purchaser's prior agreement.

DELIVERY:

The delivery deadlines mentioned on our order confirmations are only indicative.

The Seller (SIMMOB) strives in all cases to respect them but any variations in the lead time shall not entitle the Purchaser to cancel the order, or refuse the goods or claim damages.

Unless otherwise agreed, the Seller (SIMMOB) delivers the orders « Ex Works » (Incoterms 2010) Matha – France.

The Purchaser carries out all operations involving transport, insurance, customs, and bears all risks of transport loss, damage or delay, whether or not related transportation has been arranged by the Seller (SIMMOB) and even if the furniture were sold carriage free.

The risks and liability are transferred to the Purchaser at the time the products are handed over to the carrier.

FORTUITOUS EVENTS AND FORCE MAJEURE:

The Seller (SIMMOB) is relieved of any obligations with regards to the Purchaser for all fortuitous events or in case of force majeure. It is expressly agreed that events of force majeure shall be, in particular but not limited to, international tensions, war, riots, total or partial strikes, paralyzing bad weather, blocking-labor or blocking-roads situations, fire, flood, shortage of raw materials or any circumstances beyond the Seller's (SIMMOB) reasonable control.

CLAIMS:

The Purchaser should inspect the products immediately upon delivery.

Any and all claims relative to product's conformity, shall be reported to the Seller (SIMMOB) by registered letter with acknowledgment of receipt, within three days from the delivery date. Past this period, no claim will be admissible.

In the event of a compensation relative to product's conformity, the amount of such compensation shall in no case exceed the price of the product itself.

Any claim relative to transport loss or damage shall be reported to the transport company.

WARRANTY:

The Seller (SIMMOB) sells the furniture with a generic 2 years/5 years warranty. This warranty consists in the repairment or replacement of any defective components or spare parts of the products.

The warranty does not cover and is not extended to defects or damages caused by the transport or by negligence in handling, storing, using or maintaining the furniture.

Any liability and risks subsequent to the delivery, included damages to persons or goods, shall exclusively be borne by the Purchaser.

PAYMENTS:

Place of fulfillment shall be the Seller's (SIMMOB) headoffice in MATHA.

Unless otherwise agreed, payment of invoices should be made within 30 days net end of the month.

The Seller (SIMMOB) reserves the right, at any time, in accordance with incurred risks, to revoke any credit extended to the Purchaser, and to require specific payment terms or specific guarantees.

Failure to pay any single invoice at due date shall entitle the Seller (SIMMOB) to refuse or cancel any outstanding orders, and shall lead to immediate payability of any other outstanding amounts.

Returns costs, extension of benefits fees and outstanding payment fees shall always be borne by the Purchaser.

In the event of a payment default, after formal notice to the debtor by the Seller (SIMMOB), the due amounts will strictly bear interest at ECB REFI rate + ten points.

Pursuant to Article 121 of Law No. 2012-387 of 22 March 2012 a fixed indemnity of 40 euros shall apply to professionals in a situation of payment failure.

RETENTION OF TITLE:

Pursuant to Law of 12/05/1980 n° 80/335 the furniture shall be transferred to the Purchaser's ownership once and only once the Purchaser has fulfilled payment of their full price. Until then the furniture remains the Seller's (SIMMOB) property.

INTERNET POLICY – INDUSTRIAL AND INTELLECTUAL PROPERTY:

The Purchaser expressly recognizes that the Seller's (SIMMOB) name, logo, product images, pictures, trademarks, commercial names or any other distinctive marks, as well as written or electronic documents, drawings, data and information remain the exclusive property of the Seller (SIMMOB).

JURISDICTION:

In the event of a dispute, the Court of SAINTES - France shall have exclusive jurisdiction, wherever the place of delivery is.

BUROCEAN is a registered trademark of SIMMOB S.A.S.



SIMMOB S.A.S.

2, route d'Angoulême
BP 50008
17160 MATHA
FRANCE

Capital de 320 000 €
SIREN 556 580 033 00018
N° TVA FR 56 556 580 033

Tél + 33 (0)5 46 58 52 20
Tél SAV + 33 (0)5 46 58 68 37
Fax + 33 (0)5 46 58 62 09
Mail: infos@simmob.com

NOTES :

A series of horizontal dashed lines for writing notes, spanning the width of the page.



2, route d'Angoulême - BP 50008
F - 17160 MATHA - France

Tél + 33 (0)5 46 58 52 20
Fax + 33 (0)5 46 58 62 09
Email: infos@simmob.com

www.simmob.com

